



Energy Storage Battery Specification

储能电池规格书

Product ID 产品编号: C.001161

Customer No 客户编号: _____

Product Model 产品型号: LF12100-TM (马达款)

Checked & Approved by 批准	Prepared by 编制	Date 日期
邓雄华	张祥辉	 2025/05/27

Customer Approved 客户承认 (Stamp) (盖章)	Test by 测试	Checked by 审核	Approved by 批准

ShenZhen Hysincere Battery Co., Ltd

深圳市海芯电池有限公司

Tel: +86-0755- 2357 1220

Fax: +86-0755- 2357 9061

E-mail: info@hysincere.com

Website: www.hysincere.com

Add: Room 611 Building D,Bantian International Center,No.5 Huancheng South Road,Bantian Street,
Longgang District,Shenzhen,China



Revision History 修改记录

Edition 版本	Description 记述	Prepared by 编制	Approved by 批准	Date 日期
A0	First Edition 首次版本			2025/05/27



Contents 目录

1.Scope 概述	3
2.Product Configuration 产品构成	3
3.Port definitions 端口定义	4
4.Product Dimension 产品尺寸	5
5. Cell specifications 电芯规格	6
6.Battery Pack Specifications 电池组规格	7
7.Product Performance Test 产品性能测试	9
8.BMS Specification 保护板规格	13
9.Storage and Transportation 储存和运输	14
10.Battery Precautions and Safety Instructions 电池使用注意事项及安全说明	15
11.Period of Warranty 保质期	16
12.Package 包装	16
13.Label 商标	17
14.Others 其他	18
15.Special Request 特殊要求	18

1. Scope 概述

This specification applies to the rechargeable lithium iron phosphate battery pack manufactured by Shenzhen Hysincere Battery Co., LTD.

此规格书适用于深圳市海芯电池有限公司制造的可充电磷酸铁锂电池组。

2. Product Configuration 产品构成

No. 编号	Item Name 名称	Specification 规格型号	Qty 用量	Remark 备注
1	Cell 电芯	GSP50160119F-100Ah 3.2V	4	
2	BMS 保护板	4 strings lithium iron same port 120A 4串铁锂同口 120A	1	
3	Connector 插头	Red 接线端子红色(F13)M8 螺母柱	1	
		Black 接线端子红色(F13)M8 螺母柱	1	
4	Shell 外壳	ABS	1	

3. Port definitions 端口定义

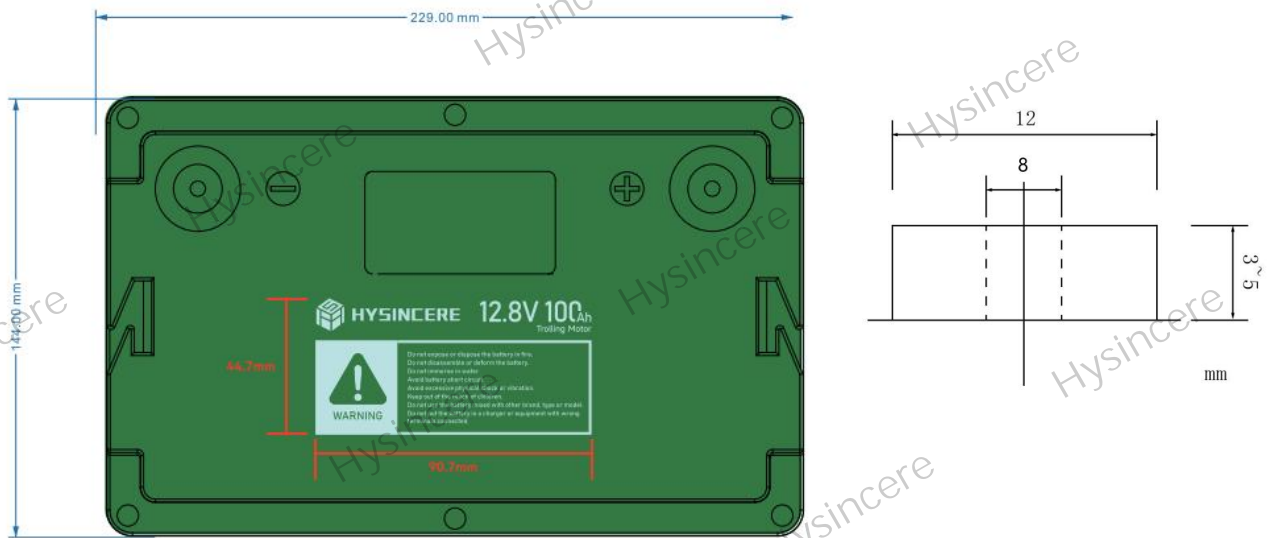

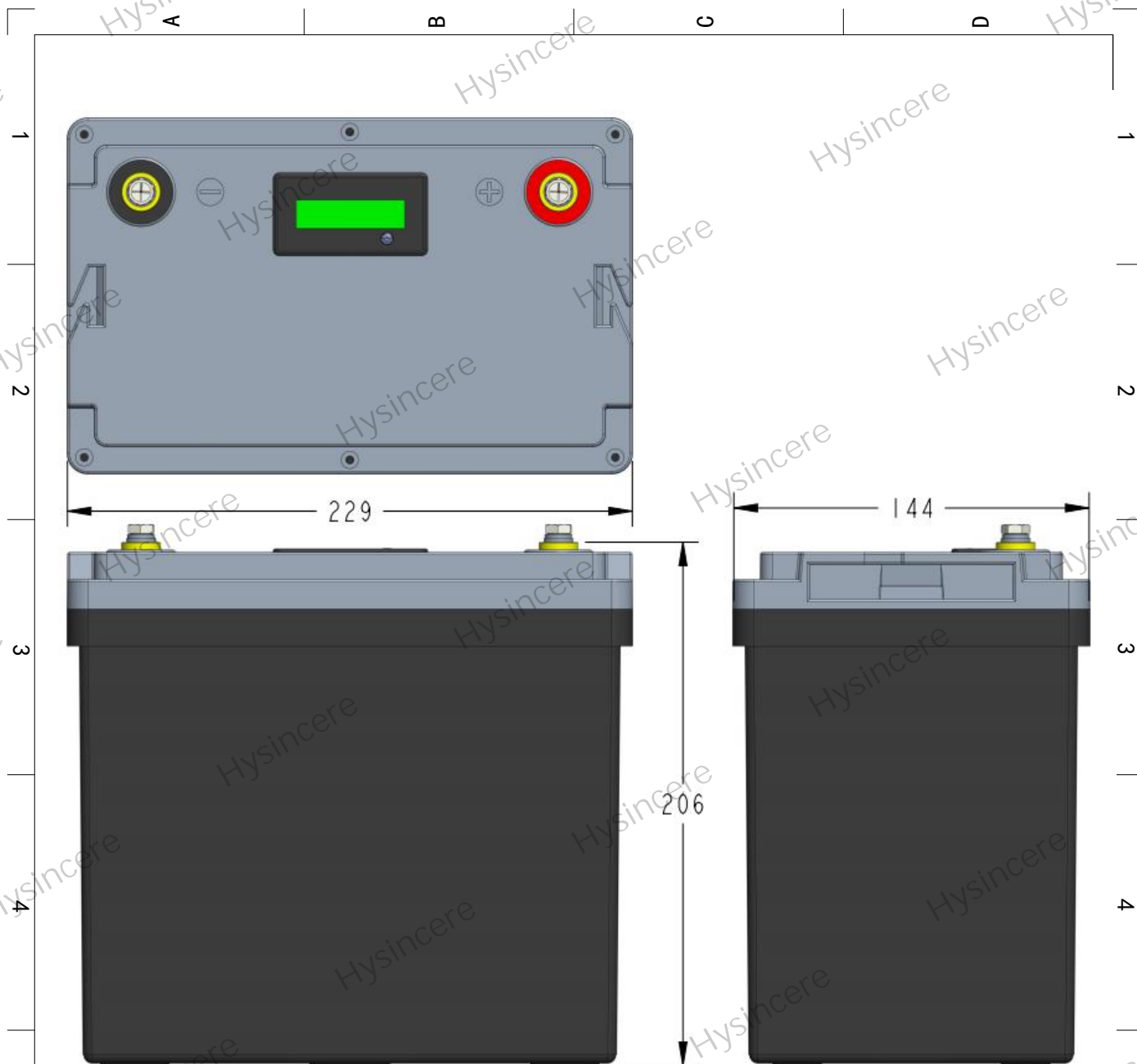
4. Product Dimension 产品尺寸

A3				未注公差		名称:	深圳海芯电池有限公司		
A2				尺寸	公差	成品尺寸图			
A1				0.5~6	±0.05	材质:	图号:		
A0				6~30	±0.1				
版本号	变更	签名	日期	30~120	±0.15	处理:	件数	单位	比例
设计				120~400	±0.5		共 1 张	mm	无
审核				400~1000	±1.0				
批准				1000~2000	±2.0				第 1 张

5. Cell specifications 电芯规格

No. 序号	Item 项目	Rated Performance 产品性能		Remark 备注
1.	Cell Model 电芯型号	GSP50160119F-100.0Ah 3.2V		
2.	Rated Capacity 额定容量	Typical 标称容量	100Ah	Discharge at 0.2C ₅ A after standard charge fully. 标准充电后 0.2C ₅ A放电
		Minimum 最小容量	100Ah	
3.	Nominal Voltage 标称电压	3.2V		
4.	Shipment voltage 出货电压	3.00~3.30V		
5.	Discharge cut-off voltage 放电终止电压	2.5V		
6.	Charging Voltage 充电电压	3.65±0.03V		
7.	Internal resistance 内阻	≤0.45mΩ		AC Impedance, 1KHz AC 1KHz 交流阻抗
8.	Standard Charge 标准充电	Constant current 0.33C ₅ A charge to 3.65V,Then constant voltage 3.65V to current below 0.05C ₅ A cutoff. 恒流 0.33C ₅ A充电至 3.65V, 然后恒压 3.65V至电流低于 0.05C ₅ A截止。		Charge time: Approx 4.0h. 充电时间约 4.0 小时
9.	Standard Discharge 标准放电	Constant Current 0.5C ₅ A end voltage 2.5V 恒流 0.5C ₅ A 放电至 2.5V		
10.	Fast Charge 快速充电	Constant current 1.0C ₅ A charge to 3.65V,Then constant voltage 3.65V to current below 0.05C ₅ A cutoff. 恒流 1.0C ₅ A充电至 3.65V, 然后恒压 3.65V至电流低于 0.05C ₅ A截止。		Charge time : Approx1.5h. 充电时间约 1.5 小时
11.	Fast Discharge 快速放电	Constant Current 1.0C ₅ A end voltage 2.5V 恒流 1.0C ₅ A放电至 2.5V		
12.	Maximum Continuous Charge Current 最大持续充电电流	1.0C ₅ A		
13.	Maximum Continuous Discharge Current 最大持续放电电流	1.0C ₅ A		Only single cell 仅限单体电芯

14.	Discharge Pulse Current 放电脉冲电流	200A	50%SOC, 30s
15.	Operation Temperature Range 工作温度范围	Charge: 0~55°C 充电: 0~55°C	≤95%R.H
		Discharge: -20~60°C 放电: -20~60°C	

6. Battery Pack Specifications 电池组规格

No. 序号	Item 项目	Rated Performance 产品性能		Remark 备注
1.	Cell Model 组合方式	4S1P		
2.	Communication Function 通讯功能	/		
3.	Way to work 工作方式	Use alone or in parallel		
4.	Rated Capacity 额定容量	Typical 标称容量	100Ah	Discharge at 0.5C ₅ A after standard charge fully. 标准充电后 0.5C ₅ A放电
5.	Nominal Voltage 标称电压	12.8V		
6.	Discharge cut-off voltage 放电终止电压	10V		
7.	Charging Voltage 充电截止电压	14.6V		
8.	Internal resistance 内阻	≤10mΩ		AC Impedance, 1KHz AC 1KHz 交流阻抗
9.	Standard Charge 标准充电	Constant current 0.33C ₅ A charge to 14.6V, Then constant voltage 14.6V to current below 0.02C ₅ A cutoff. 恒流 0.33C ₅ A 充电至 14.6V, 然后恒压 14.6V 至电流低于 0.02C ₅ A 截止。		Charge time: Approx 4.0h. 充电时间约 4.0 小时
10.	Standard Discharge 标准放电	Constant Current 0.5C ₅ A end voltage 10V 恒流 0.5C ₅ A 放电至 10V		
11.	Fast Charge 快速充电	Constant current 1.0C ₅ A charge to 14.6V, Then constant voltage 14.6V to current below 0.02C ₅ A cutoff. 恒流 1.0C ₅ A 充电至 14.6V, 然后恒压 14.6V 至电流低于 0.02C ₅ A 截止。		Charge time : Approx 1.5h. 充电时间约 1.5 小时



深圳市海芯电池有限公司

SHENZHEN HYSINCERE BATTERY CO.,LTD.

12.	Fast Discharge 快速放电	Constant Current 1.0C ₅ A end voltage 10V 恒流 1.0C ₅ A放电至 10V	
13.	Maximum Continuous Charge Current 最大持续充电电流	100A	
14.	Maximum Continuous Discharge Current 最大持续放电电流	100A	
15.	Discharge Pulse Current 放电脉冲电流	500A	≤8S
16.	Operation Temperature Range 工作温度范围	Charge: 0~55°C 充电: 0~55°C	60±25% RH.
		Discharge: -20~60°C 放电: -20~60°C	
17.	Weight 重量	Approx:8.95Kg 约: 8.95Kg	
18.	Product Dimension 产品尺寸	Length: 229±5mm 长度: 229±5mm	
		Width: 144±5mm 宽度: 144±5mm	
		Height: 206±5mm 高度: 206±5mm	
19.	Energy Extension 能量扩展	Max. 4 units in parallel 最大支持 4 个单元并联 Max.Support up to 4 units in series 最大支持 4 个单元串联	The pressure difference of the battery should be less than 500mV when connected in parallel. 电池并联压差小于 500mV
20.	Ingress Protection 防护等级	IP67	

7. Product Performance Test 产品性能测试

7.1 Standard Testing Conditions

标准测试条件

The test should be conducted with fresh battery within one week after shipment and the battery shall not be cycled more than five times. Unless otherwise defined, the test and measurement shall be done under temperature of $23\pm 2^{\circ}\text{C}$ and relative humidity of 45~85%. Normally, the temperature and relative humidity will not affect the test results when they are at a range of temperature 15~30°C and humidity 25~85%RH.

测试样品为出厂一周以内新电池，循环次数 5 次以下。测试环境温度为 $23\pm 2^{\circ}\text{C}$ ，湿度为 45~85%，一般情况下，测试数据在以下的环境中应该不会受到明显影响：温度 15~30°C，湿度 25~85%。

7.2 Measuring Instrument or Apparatus

测试的设备仪器

7.2.1 Dimension Measuring Instrument

外形尺寸测试设备

The dimension measurement shall be implemented by instruments with equal or more precision scale of 0.01mm.

游标卡尺，精度 0.01mm

7.2.2 Volt meter

电压计

Standard class specified in the national standard or more sensitive class having inner impedance more than $10\text{k}\Omega/\text{V}$

精确程度高于等于国标，内阻大于 $10\text{k}\Omega/\text{V}$

7.2.3 Ammeter meter

电流表

Standard class specified in the national standard or more sensitive class. Total external resistance including ammeter and wire is less than 0.01Ω .

精确程度高于等于国标，内阻小于 0.01Ω

7.2.4 Impedance Meter

内阻仪

Impedance shall be measured by a sinusoidal alternating current method (1kHz LCR meter).

交流电方法测量，参数 (1kHz LCR meter)

7.3 Standard Charge\Discharge

标准充放电

7.3.1 Standard Charge

标准充电：

CC-CV 恒流-恒压

Test procedure and its criteria are referred as follows:

测试程序和标准要求如下：

$0.33\text{C}_5\text{A} = 33\text{A}$

Charge with $0.33\text{C}_5\text{A}$ constant current until the battery reaches 14.6V, Then charge with voltage 14.6V until the charging current drops to 2.0A. The charge will be terminated and the battery shall be fully charged. Charge time is Approx 4.0h. The battery shall be with no permanent degradation when charged between 0°C and 55°C .

以 $0.33\text{C}_5\text{A}$ 持续充电至电池电压达到 14.6V，然后以 14.6V 的恒定电压继续给电池充电，直到充电



深圳市海芯电池有限公司

SHENZHEN HYSINCERE BATTERY CO.,LTD.

电流小于 2.0A。充电时间大约为 4.0h。在温度为 0°C—55°C 范围内充电应该显示电池无损坏。

7.3.2 Standard Discharge

标准放电

0.5C₅A =50A

Battery shall be discharged at a constant current of 0.5C₅A to 10V @ 23±2°C.

电池以 0.5C₅A 的恒定电流放电到 10V，环境温度为 23±2°C。

7.4 Appearance

外观

There shall be no such defects as flaw, crack, rust, leakage, which may adversely affect commercial value of battery.

外观整洁，电池无破损，无污渍，露液和腐蚀。

7.5 Initial Performance Test

化学性能测试

Item 项目	Measuring Procedure 测试方式	Requirements 要求指标
Open-Circuit Voltage 开路电压	The open-circuit voltage shall be measured within 24 hours after standard charge. 标准充电之后 24 小时内测量开路电压	≥13.6V
AC Impedance Resistance 内阻	The Impedance shall be measured in an alternating current method (1kHz LCR meter) after standard charge at 23±2°C. 23±2°C 状态下标准充电后测量内阻，交流电方法测量，参数（1k 赫兹 LCR 内阻仪）	≤10mΩ
Nominal Capacity 标称容量	The capacity measured after standard discharge at 0.33C ₅ A at 23±2°C. 23±2°C 状态下电池 0.33C ₅ A 放电时的放电容量	Discharge Capacity ≥100Ah
Retention Capability 荷电保持能力	After charge fully, store the battery for 28 days at 23±2°C, then store 1 hours more, then discharge the battery at current of 0.2C ₅ A till 10V cut-off voltage. 电芯满充电后，在 23±2°C 的环境条件下存放 28 天，搁置 1h 后以 0.2C ₅ A 电流连续放电至 10V 终止电压。	Capacity≥90% 容量≥90%

7.6 Discharge capacity at different temperatures

不同温度放电容量表现

Battery shall be charged per 5.3.1. and discharged @ 1.0C₅A to 10V at different temperatures, the discharge capacities are as shown in below . The battery shall be stored for 3 hours at the test temperature before test. Each battery shall meet or exceed the discharge capacities as shown in below .

以标准电流充电后，电池以 1.0C₅A 放电到 10V，电池在各种温度条件下的放电数据如下表。测试前电池要在测试温度环境中静置 3H，然后再进行放电测试。测试后的数据应达到或超过下表数据。

Discharge Temperature 放电环境温度	-20°C	-10°C	0°C	10°C	23°C	55°C
Discharge Capacity (0.2C ₅ A) 放电容量 (0.2C ₅ A)	70%	75%	80%	90%	100%	90%

7.7 Cycle Life and Leakage-Proof

循环寿命及漏液测试

No. 序号	Item 项目	Criteria 测试要求	Test Conditions 测试方法
1	Cycle Life 循环寿命	Higher than 80% of the Typical Capacities of the battery 高于标称容量 80%	Carry out 2000 cycles charging/discharging: 以下方式进行 2000 次充放电: ◆Charge: Standard Charge, per 7.3.1 充电:按照 7.3.1 的标准充电 ◆Discharge: 0.5C ₅ A to 10V 放电: 0.5C ₅ A 放电至 10V ◆Rest Time between charge/discharge:30min. 充放电之间静置 30min ◆Temperature:23±2°C 温度:23±2°C
2	Leakage-Proof 漏液	No leakage (visual inspection) 无漏液(目测)	After fully charged, store at 60±3°C,60±10%RH for 1 month. 满充电,在 60±3°C 温度及 60±10% 湿度状态放置 30 天

7.8 Mechanical Characteristics and Safety Test

安全测试及机械特性

Item 项目	Battery Condition 电池状况	Test Method 测试方法	Requirements 要求
Over charge test 过充测试	Fresh battery, Fully Charged 新电池带电量 100%	Discharge: 0.5C ₅ A to 10V Charge: 1.0C ₅ A charge to 14.6V, and maintain for 1 hours. 放电: 0.5C ₅ A 放电至 10V 充电: 1.0C ₅ A 充电至 14.6V, 保持 1 小时	No explosion No fire 不爆炸, 不起火
Over discharge test 过放测试	Fresh battery, Fully Charged 新电池带电量 100%	Discharge at constant current 0.5C ₅ A to 10V, then discharge at 0.2C ₅ A to 0V. 0.5C ₅ A 恒流放电至 10V, 然后 0.2C ₅ A 放电到 0V。	No explosion no fire, no smoke 不爆炸, 不起火 不冒烟
Heat shock test 热冲击测试	Fresh battery, Fully Charged 新电池带电量 100%	Put the battery in hot box ,then heat up to 130°C in 5±2°C/min rate, remain for 10 minutes. 把电池放进热箱里, 然后以 5±2°C/min 速率升高到 130°C, 并保持 10 分钟。	No explosion No fire 不爆炸, 不起火
Heavy impact test 重物冲击试验	Fresh battery, Fully Charged 新电池带电量 100%	Impact between bar (15.8mm diameter) and 9.1Kg falling material (at a height of 6.1cm). Bar is laid across the center of the test sample. 将直径为 15.8mm 的金属棒横放在电池的大面中间, 将 9.1Kg 的重物在金属棒的上方 6.1cm 的高处自由落下冲击金属棒。	No explosion No fire 不爆炸, 不起火

Crush Test 挤压测试	Fresh battery, Fully Charged 新电池带电量 100%	Crush between two flat plates. Applied force is about 13kN(1.72Mpa) for 10min. 平放于两块水平的金属板之间，施以 13kN(1.72Mpa) 力静置 10 分钟。	No explosion, No fire 不爆炸，不起火
Short Circuit test 短路测试	Fresh battery, Fully Charged 新电池带电量 100%	Make short-circuited by connecting the (+) and (-) terminals of the battery with a copper wire having a maximum resistance load of 0.1Ω. Tests are to be conducted at room temperature (23±2°C). 在 23±2°C 温度环境中，用内阻低于 0.1Ω 的导线将电池正负极直接连接。	No explosion, No fire. The surface of the battery shouldn't exceed 150°C 不爆炸，不起火，电池表面温度不超过 150°C
Rate test 倍率测试	Fresh battery, Fully Charged 新电池带电量 100%	0.2C/0.5C/1.0 charge & discharge.	
Low temperature discharge test 低温放电测试	Fresh battery, Fully Charged 新电池带电量 100%	Put the battery at -20°C for 1h, then discharge at 1.0C ₅ A to 10V. 把电池放到 -20°C 环境保持 1h，1.0C ₅ A 放电至 10V	Discharge capacity ≥70% 放电容量 ≥70%
Store for 7 days 60°C 55°C 储存 7 天	Fresh battery, Fully Charged 新电池带电量 100%	The batteries charged under standard conditions at 25±3°C, are stored at ambient temperature 55±3°C for 7 days. Measure the 0.5C capacity after 7 days at 25±3°C . 将电池在 25±3°C 标准充电后，储存在 55±3°C 的环境中 7 天，7 天后测试电池在 25±3°C 环境下 0.5C 容量	Capacity retention ≥93% Capacity recovery ≥95% 容量保持 ≥93% 容量恢复 ≥95%
Vibration test 振动测试	Fresh battery, Fully Charged 新电池带电量 100%	Vibrate the battery for 30 minutes per each three mutually perpendicular axis (X,Y,Z) after standard charge. 标准充电后，X、Y、Z 每个方向振动 30 分钟。	No rupture, no fire. No critical damage. 不破裂，不起火，无严重损坏
Drop test 跌落测试	Fresh battery, Fully Charged 新电池带电量 100%	Drop the battery from a height of 1m onto concrete board with 18~20mm thickness each one time from every direction after standard charge. Then discharge and charged at 1C 3 times, record the time of discharging. 标准充电后，从 1m 高的位置每个方向跌落 1 次，然后以 1C/1C 循环 3 次，记录放电时间	No rupture, no fire No critical damage. Discharge time ≥51min 不断裂，不起火，无严重损伤 放电时间 ≥51min

8.BMS specifications 保护板规格

8.1 Electrical features 电气特性:

Project 项目	Parameter value 参数值			
	Min. 最小	Type 典型	Max.最大	Unit 单位
Over charge protection voltage 过充保护电压	3.65	3.70	3.75	V
Over charge release voltage 过充保护恢复电压	3.55	3.60	3.65	V
Over discharge protection voltage 过放保护电压	2.15	2.20	2.25	V
Over discharge release voltage 过放保护恢复电压	2.55	2.60	2.65	V
Charge over current protection current 充电过流保护电流	/	/	/	A
Discharge over current protection current 放电过流保护电流	200	/	300	A
Over charge protection delay time 过充保护延时	500	1000	1500	ms
Over discharge protection delay time 过放保护延时	500	1000	1500	ms
Over current protection delay time 过流保护延时	7000	10000	13000	ms
Short protection 短路保护	900	/	1200	A
Short protection delay time 短路保护延时	160	400	560	us
Active Balance Current 平衡电流	40	/	80	mA
Current consumption (Operation) 工作自耗	/	/	100	uA
Impedance 内阻	/	/	20	mΩ
Input voltage (B+ to B-) 输入电压	-0.3	-	15	V
Operating temperature 工作温度	-29	-	+69	°C
0V battery charge function 0V 充电功能	Available			
Communication Function 通讯功能	/			

9. Storage and Transportation 储存和运输

9.1 Storage 储存:

9.1.1 The Li-ion battery pack should be stored in a cool, dry and well-ventilated area and should be kept far away from the fire and high temperature.

锂离子电池应该储存在低温、干燥和通风良好的地方，远离有火和高温的地方。

9.1.2 The best capacity for storage is 30%-50% .

存储电池最合适的带电量为 30% - 50% 带电。

9.1.3 The battery should be stored in the temperature range as stated in this specification sheet. The best storage temperature is 0 to 25°C. The best humidity is 60±25%.

电池应该在本规格书规定的温度范围内存放。最好的存放温度为 0 ~25°C。最佳存放湿度为 60±25% 。

9.1.4 If store the battery six months or longer, suggest carry on additional charge to the battery.

如果有超过六个月以上的长时间存储,建议进行额外的电池充电。

9.2 Transportation 运输:

9.2.1 Do not mix the battery products with other cargoes.

不要将电池和其他的产品混装。

9.2.2 Do not immerse the battery products in water or get it wet.

不要将电池产品置于水中或是使电池受潮。

9.2.3 Do not do over 4 layer- staking and upside-down.

不要将电池放置超过 4 层和倒置电池。

9.2.4 The highest temperature in transportation is lower than 60°C.

运输电池时最高的温度要低于 60°C。

10. Battery Precautions and Safety Instructions:

电池使用注意事项及安全说明

To ensure proper use of the battery please read the instructions carefully before using it.

为了确保电池的安全和正确使用，请在使用电池之前仔细阅读以下内容。

10.1 Handling 操作:

10.1.1 Do not expose or dispose the battery in fire.

电池不要暴露于或者放置于有火的地方。

10.1.2 Do not put the battery in a charger or equipment with wrong terminals connected.

在充电或接入用电器时，注意正负极不要接反。

10.1.3 Avoid battery short circuit.

请勿将电池短路。

10.1.4 Avoid excessive physical shock or vibration.

避免过分的敲击及震动电池。

10.1.5 Do not disassemble or deform the battery.

请勿拆解电池或使电池变形。

10.1.6 Do not immerse in water.

请勿浸入水中。

10.1.7 Do not use the battery mixed with other brand, type or model.

请勿不同厂家、不同类型、不同型号混用。

10.1.8 Keep out of the reach of children.

避免让儿童接触到。

10.2 Charge 充电:

10.2.1 Battery must be charged in appropriate charger only.

电池必须使用适用的充电器充电。

10.2.2 Never use a modified or damaged charger.

不要使用修理过的或是已损坏的充电器充电。

10.2.3 Do not leave battery in charger over 24 hours.

不要让电池充电超过 24 个小时。

10.2.4 Charging current: Don't surpass the highest charge current as stated in this specification sheet.

充电电流: 不能高于本规格书规定的充电电流上限。

10.2.5 Charging voltage: Don't surpass the highest charge voltage as stated in this specification sheet.

充电电压: 不能高于本规格书规定的充电电压上限。

10.2.6 Charge temperature: The battery must be charged in the ambient temperature range as stated in this specification sheet.

充电环境温度: 必须在本规格书规定的温度范围内进行充电。

10.2.7 Charge the battery via constant current first and then via constant voltage, no reverse charge. If the positive electrode and the cathode mixed, the battery can be damaged.

先恒流后恒压充电, 不可反向充电。如果电池的正负极接触将会损伤电池。

10.2.8 Store the battery after it's charged. The battery should be recharged/re-discharged every 3 months.

电池存放时, 必须带电态储存, 并要求每 3 个月进行一次充放电。

10.3 Discharge 放电:

10.3.1 The discharge current shouldn't surpass the highest discharge current as stated in this specification sheet. If surpass, the battery may be damaged and it can result in hot battery which is risk.

放电电流不能高于本规格书规定的放电电流上限, 过高的放电电流可能导致电池容量受损, 并可能导致电池体过热而造成危险。

10.3.2 Discharge temperature range: The discharge must be done in the ambient temperature range as stated in this specification sheet.

放电环境温度: 必须在本规格书规定的温度范围内放电使用。

10.3.3 Over-discharge: A short-time over-discharge will not affect the use of the battery, but long-time will do. If the battery is not used for a long time, the performance will get poorer. It should be recharged and re-discharged fully several times before it's recovered.

过放: 瞬间过放不影响使用, 但长时间的过放会影响电池性能。如果电池长期不使用, 电池性能也会降低, 使用时需做几次充分的充放电后才能恢复。

10.4 Disposal 处置:

Regulation is vary in different countries. Please dispose wasted battery according to local regulations.

依据使用当地的法规处理废旧电池。

11. Period of Warranty 保质期

There is a 24-month warranty of the batteries from the date of shipment. If there is quality problem within, we are responsible to replace the defective ones according to the accurate analysis results. However, we won't take any responsibility if the problem is caused by the battery-related applications and related products.

电池出厂后, 有 24 个月的保质期。在此期间内, 正常使用情况下, 电池性能表现不良者给予更换。但是如果是由电池应用的产品本身导致的不良, 我们将不负责任。

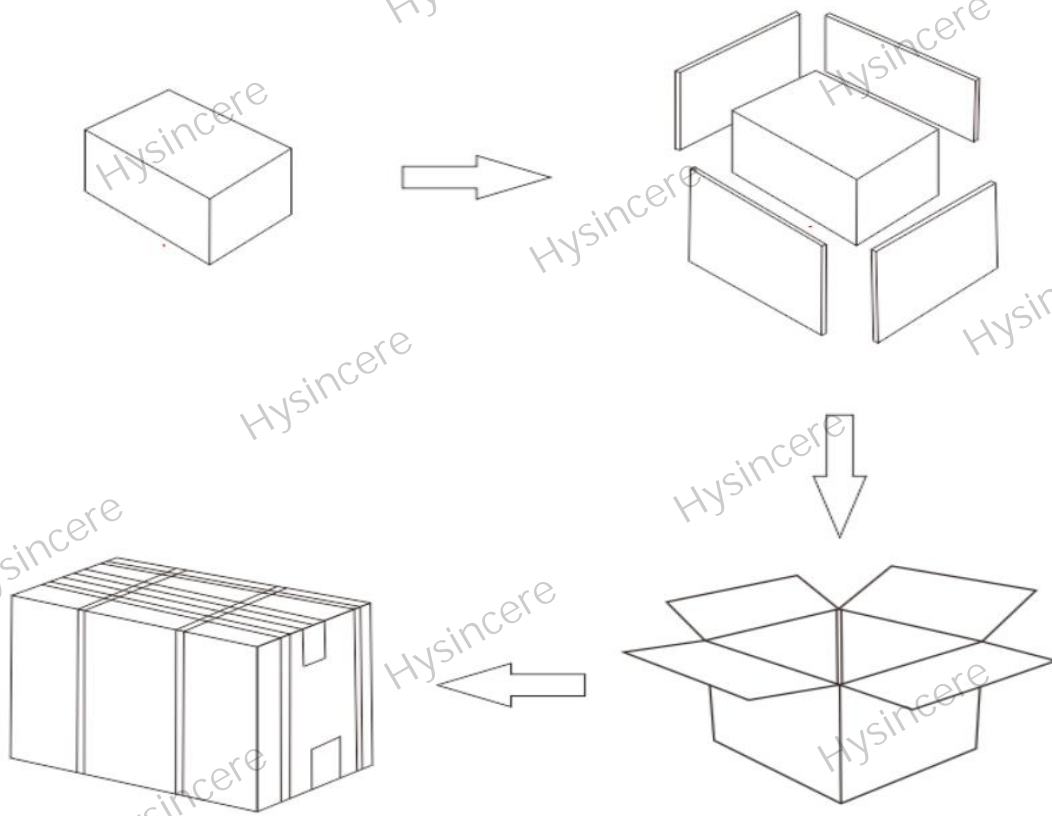
12. Package 包装图示意图

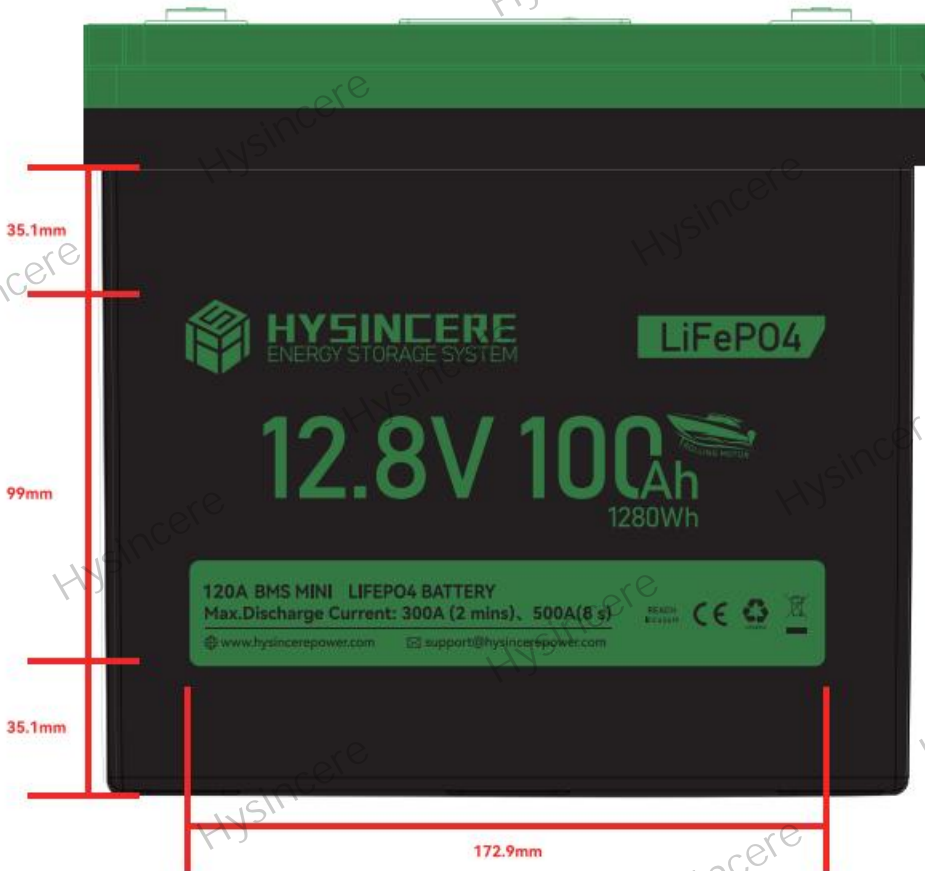
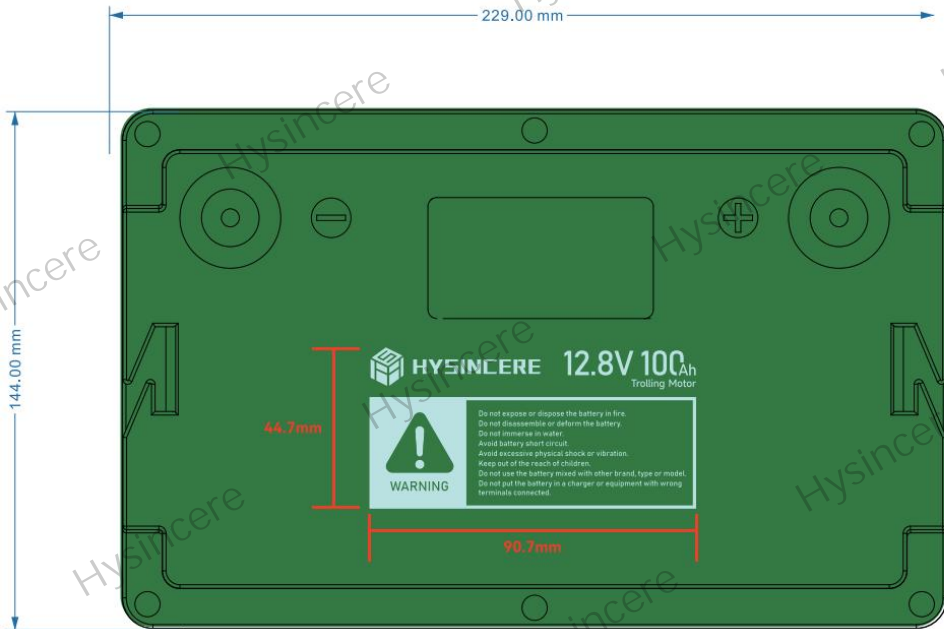
13. Label 商标
顶部

正面



14. Others 其它

Battery is chemical product, the performance will be deteriorated when it's used for a long time or it's stored for a long time without being used. In addition, if it's not charged or discharged properly as stated in this specification sheet, the capacity and lifespan will be shortened, or the product which the battery applied to will be damaged by its leaking. If the battery is charged properly but can't be charged fully, please replace it in time.

电池为化学制品，长期使用或长期贮存不用都会造成电池性能变差。如果使用条件如充电，放电，环境温度等超出了规格书规定的范围，电池的容量和寿命会缩短或者使用该电池的设备会由于漏液收到损害。如果电池采用正确的方法长时间充电而不能充满的话，就需要及时更换电池。

15. Special Request 特殊要求

If you need isn't fulfilled by this specification, we can custom design per you request. Just write down your request, we're more than happy to serve you. Thank you.

如果这个规格书的电池没能满足你的要求，请写下你的要求，我们可以为您定制，并将竭诚为您服务。谢谢！

	Special Request 特殊要求	Criteria 标准
1		
2		
3		
4		
5		
6		

ShenZhen Hysincere Battery Co., Ltd

深圳市海芯电池有限公司

Tel: +86-0755- 2357 1220

Fax: +86-0755- 2357 9061

E-mail: info@hysincere.com

Website: www.hysincere.com

Add: Room 611 Building D,Bantian International Center,No.5 Huancheng South Road,Bantian Street,
Longgang District,Shenzhen,China